



Temptronic



## Introducing the RapidTemp™ BT28 ThermoStream®

### Elevate Your Benchtop Testing Experience

Join us in embracing the future of benchtop thermal testing. Discover how our space-saving, high-speed, temperature forcing technology can help you stay ahead of the competition while maximizing your workspace.



inTEST Thermal Solutions  
Precision Temperature Control for a Dynamic World

# RapidTemp™ BT28 ThermoStream®

**-28° to +225°C**

At inTEST Thermal Solutions, we understand that innovation doesn't always need to occupy a large footprint. That's why we proudly introduce the RapidTemp™ BT28 ThermoStream®, a compact yet immensely powerful temperature test system engineered to redefine your benchtop thermal testing experience.

## UNPARALLELED PERFORMANCE IN A SMALL PACKAGE

- ◆ **Extreme Temperature Control:** Achieve precise and reliable temperature control across the widest temperature ranges with the highest airflow rates available in a benchtop test system.
- ◆ **Space-Saving Brilliance:** Designed to quickly and accurately test devices. Maximize your workspace while delivering industry leading thermal capacity.
- ◆ **SwiftTherm™ Technology:** Accelerate your product development and manufacturing timelines with lightning-fast temperature transitions.
- ◆ **ECO-Stream Design:** Engineered to be smaller, quieter, and more energy-efficient, enhancing your user experience while minimizing environmental impact.
- ◆ **Detachable Touchscreen Interface:** Enjoy the ease and convenience of a touchscreen that can be placed wherever you need it within the length of the remote cable (provided cable is 9 ft.).



Operator Screen



Data Graphing Screen

## CONTROLLER FEATURES:

- Embedded Control System
- Local & Remote Operations
- User Defined Temperature Limits
- Customizable and savable test setups
- Ethernet, IEEE-488, RS232, USB Serial ports
- Datalog Storage (USB)



# Performance and Specifications

PERFORMANCE	
Temperature Range* No LN2 or LCO2 Required	-28 to +225°C
Transition Rate*	-10 to +125°C, approx. 10 seconds or less +125 to -10°C, approx. 10 seconds or less
System Airflow Output*	14scfm

\*Under nominal operating conditions

TEMPERATURE CONTROL	
Temperature Display & Resolution	+/- 0.1°C
Temperature Accuracy	1.0°C (when calibrated against NIST standard)
DUT Temperature Control	Proprietary control algorithm enables DUT temperature to be directly controlled
DUT Sensor Ports	Thermocouples (T & K), Diode

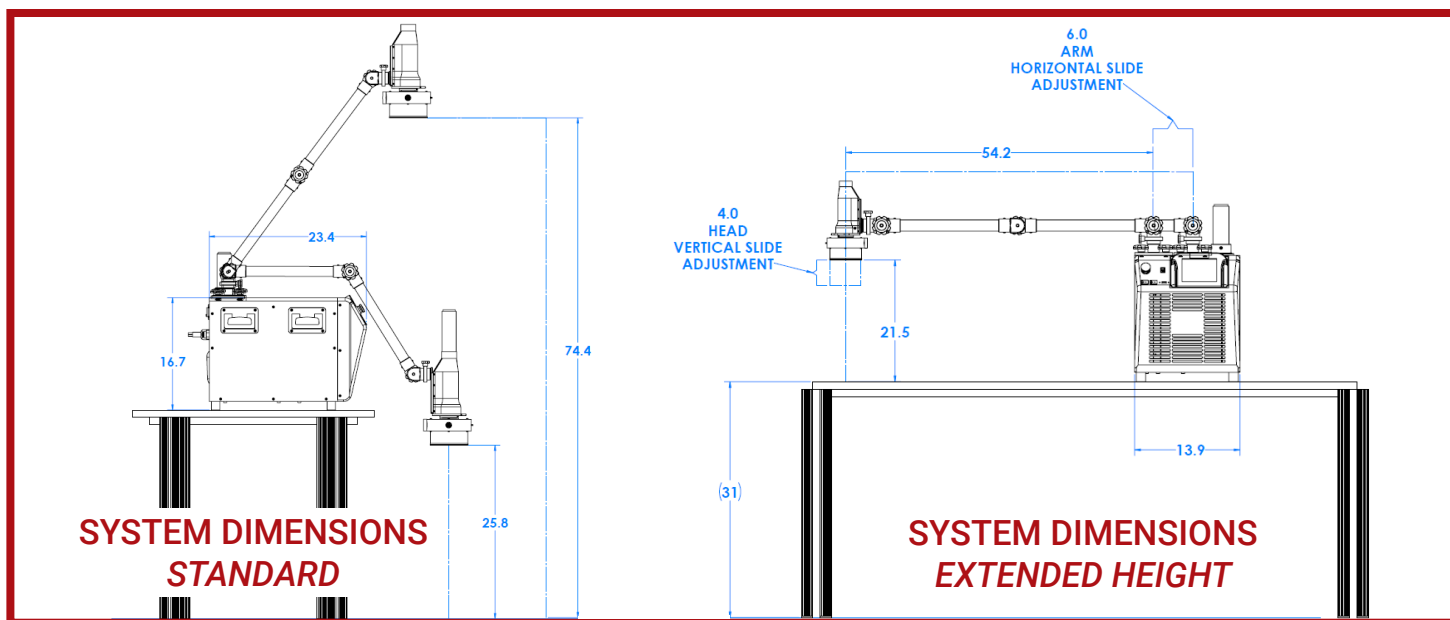

WEIGHTS & DIMENSIONS	
Base	Width: 35.4 cm (13.9 in.) Depth: 59.5 cm (23.4 in.) Height: 42.5 cm (16.7 in.) Note: An additional 15.24cm (6 in.) clearance is required for supply connections and ventilation.
System Weight	System weight: 38.3 kg (80 lbs.) Without arm or head: 31.8 kg (70 lbs.)
Mobility	Benchtop
Maximum Reach	
Maximum Operating Height	110.3 cm (43.4 in.)
Noise Level	<60dBA flow on, <50db idle

SERVICE & SAFETY	
Refrigerants	HCFC and CFC-free, non-toxic, non-flammable 0.58 Tonnes F-Gas CO2 equivalent
Serviceability	Auto-diagnostics and field replaceable modules
Over Temperature Protection	+225°C (factory set): Operator can set high and low air temperature limits



## FACILITY REQUIREMENTS

Power	Power Configurations: 115V +/-10% VAC, 60 Hz, 20 Amp; 200 to 230V +/-10% VAC, 60 Hz, 15 Amp; 200 to 230V +/-10% VAC, 50 Hz, 15 Amp Note: 115V systems high temperature limited to +200°C System configured for operation within voltages listed above using an internal transformer. Please specify voltage and frequency requirements with sales order.
<b>COMPRESSED AIR</b>	
Clean, Dry Air (CDA)	Filtered to 5 micron particulate contamination   Oil Content: <0.01 ppm, by weight, filtered to 0.01 micron oil contaminant   Dew point: -40°C (ideal) @ 6.2 BAR (90PSI) Note: Higher Dew points will require the (optional) Air Dryer unit.
Note: Avoid creating back pressure at the main nozzle. The maximum allowable back pressure is 3PSI or lower.	
Air Supply Pressure	6.2 to 7.6 BAR (90 to 90 PSIG)
Air Supply Temperature	+20 to +25°C; +22°C nominal
<b>OPERATING ENVIRONMENT</b>	
Operating Temperature	+20 to +28°C; +23°C nominal
Humidity	0 to 60%; 45% nominal
Note: Under operating conditions which are greater or less than nominal, performance may be less than specification provided.	

## RapidTemp™ BT28 ThermoStream® Accessories



### Thermal Caps (T-Caps)

Non-conductive, ESD safe glass enclosures to isolate the test subject and direct air flow. Connects directly to the BT28 nozzle.

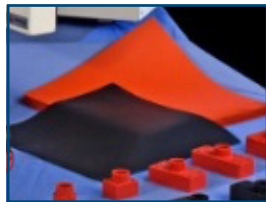

### Non-Conductive Mats

Mats and pads to insulate the test area and reduce heat loss while allowing convenient access to wired devices.



### High Performance Air Dryer

A standalone air dryer to assist in drying facility air supply ensuring optimal operating conditions and performance.



### Flex Extenders™

Interlocking, heavy duty, thermally-insulated hoses that connect the ThermoStream to test enclosures and custom test setups.



### Custom Enclosures

Custom enclosures available. We offer a wide range of shapes, sizes with considerations for test access and frost remittance.

## About inTEST Thermal Solutions

inTEST Thermal Solutions (iTS) specializes in the design and manufacture of thermal test, process cooling, and biomedical cold storage systems. Our breadth of products and in-house engineering capabilities allow us to be a single-partner-solution for precision temperature control needs. We are recognized globally for our expertise in control of extreme thermal environments, from -185 to +500°C, with rapid transitions or long dwell times. The iTS family includes four product brands: Temptronic, Sigma Systems, Thermonics, and North Sciences. inTEST Thermal Solutions is a wholly owned subsidiary of inTEST Corp., Mount Laurel, New Jersey, USA. (NYSE: INTT).